

Objects and Processes in the “Aristotelian” Space-Time

We have introduced:

- the general concept of space-time as an assemblage, or repository, of events
- the “Aristotelian” framework (set-up), which is a particular attitude about what relationships there are between and among events

The Aristotelian view provides a characterization of every event by four numbers, three representing its location in space, in three spatial dimensions in reference to some useful Cartesian coordinate system (e.g., a room) and one other representing the time of its occurrence.

A (Gerochian) procedure for assigning these numbers to events: observers, badges, watches, etc.

Each event is uniquely characterized by four numbers = Every event is located at a certain point of a four-dimensional space-time.

(Nothing very deep or mysterious here)

Today:

- ☞ Introduce a useful technique for assigning space and time coordinates to events
- ☞ Learn to translate back and forth between geometrical constructs in space-time and various goings-on in the physical world

“Cube” as the Main Tool

- ☞ Suppress one dimension of space (usually z)
- ☞ Cube boundaries do *not* represent a “boundary” of space-time

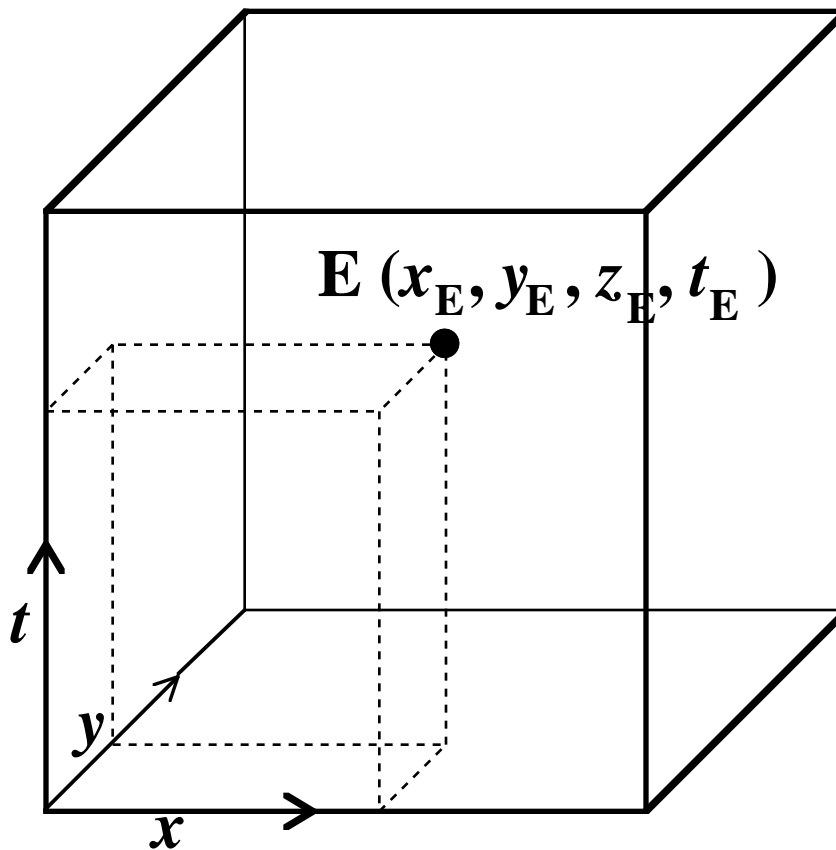

Positions in Space

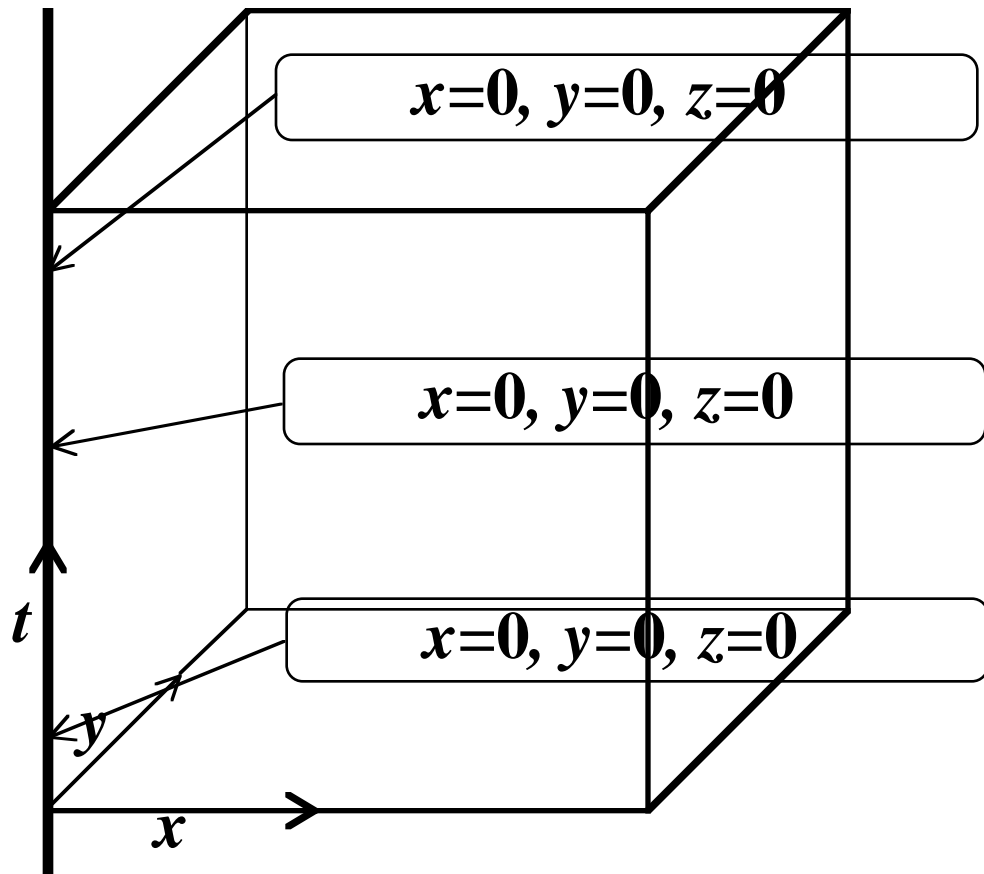

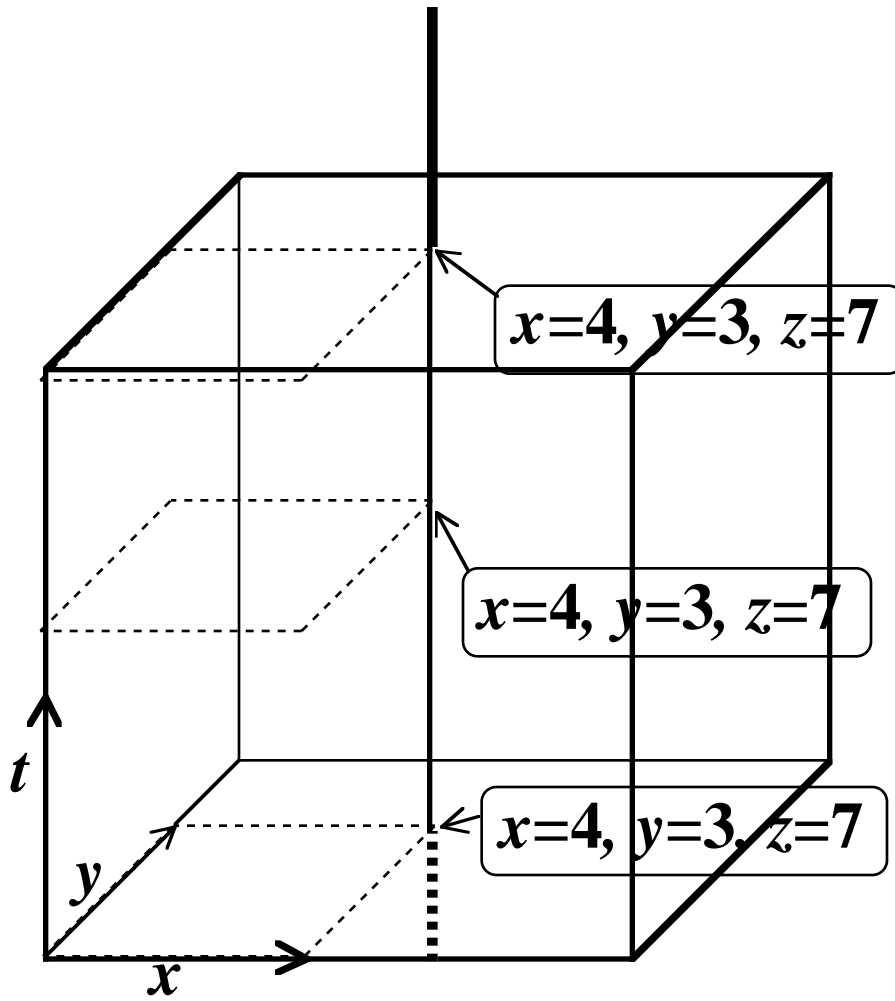

Times of Occurrences of Events

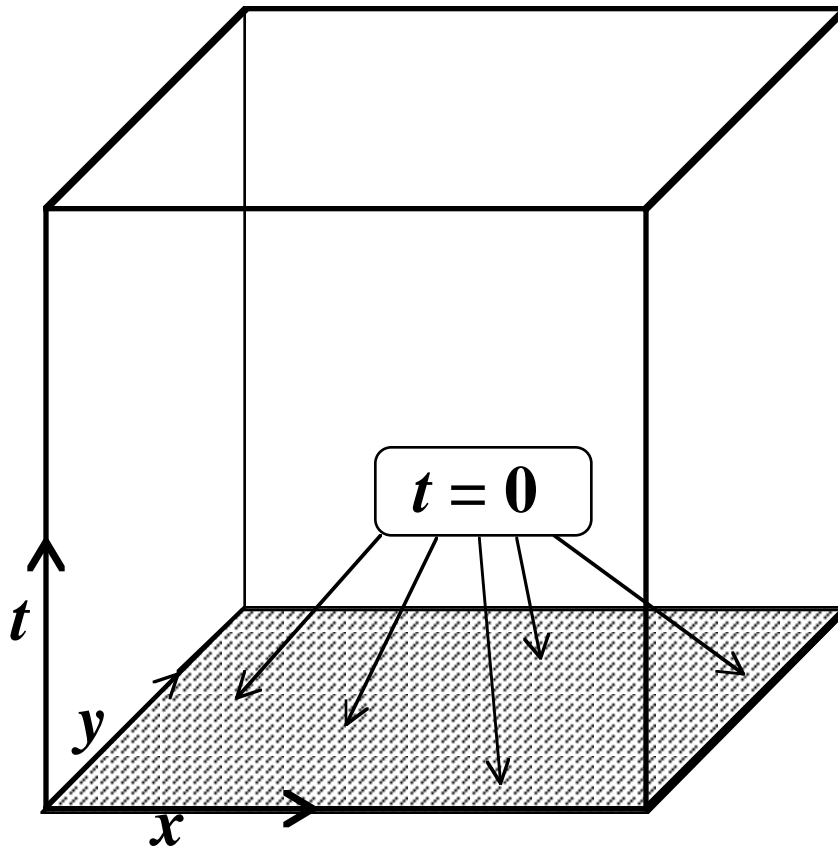

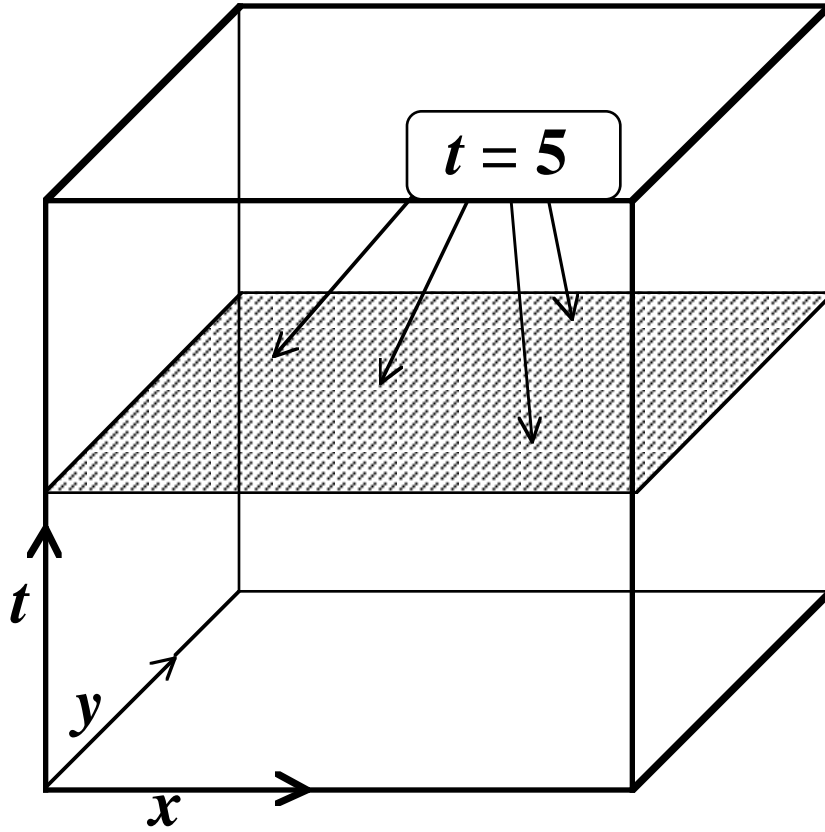

- ☞ Vertical lines correspond to “positions in space”
- ☞ Horizontal 3-planes correspond to “times of occurrence”

Important Contrasts:

In the usual three-dimensional space, positions in this space are represented by *points*.

In the four-dimensional space-time, positions in space are associated with *lines*, namely with world-lines of observers at rest, that is, vertical straight lines

In ordinary life, times are represented by *numbers* (i.e., watch-readings)

But the geometrical way of representing the time of a certain occurrence in space-time, in the four-dimensional space-time manifold, is by a *plane*

- ☞ Reformulate our older characterization of events in the Aristotelian framework in a more geometrical language—the language of space-time.

The old characterization:

An event is naturally characterized by giving its position in space together with the time of its occurrence.

A new characterization, in terms of points in space-time, which represent events:

A point of space-time (representing an event) is naturally characterized by giving the vertical straight line on which it lies (representing the position, or location, of the event in space) together with the horizontal 3-plane on which it lies (representing the time of the occurrence of the event).

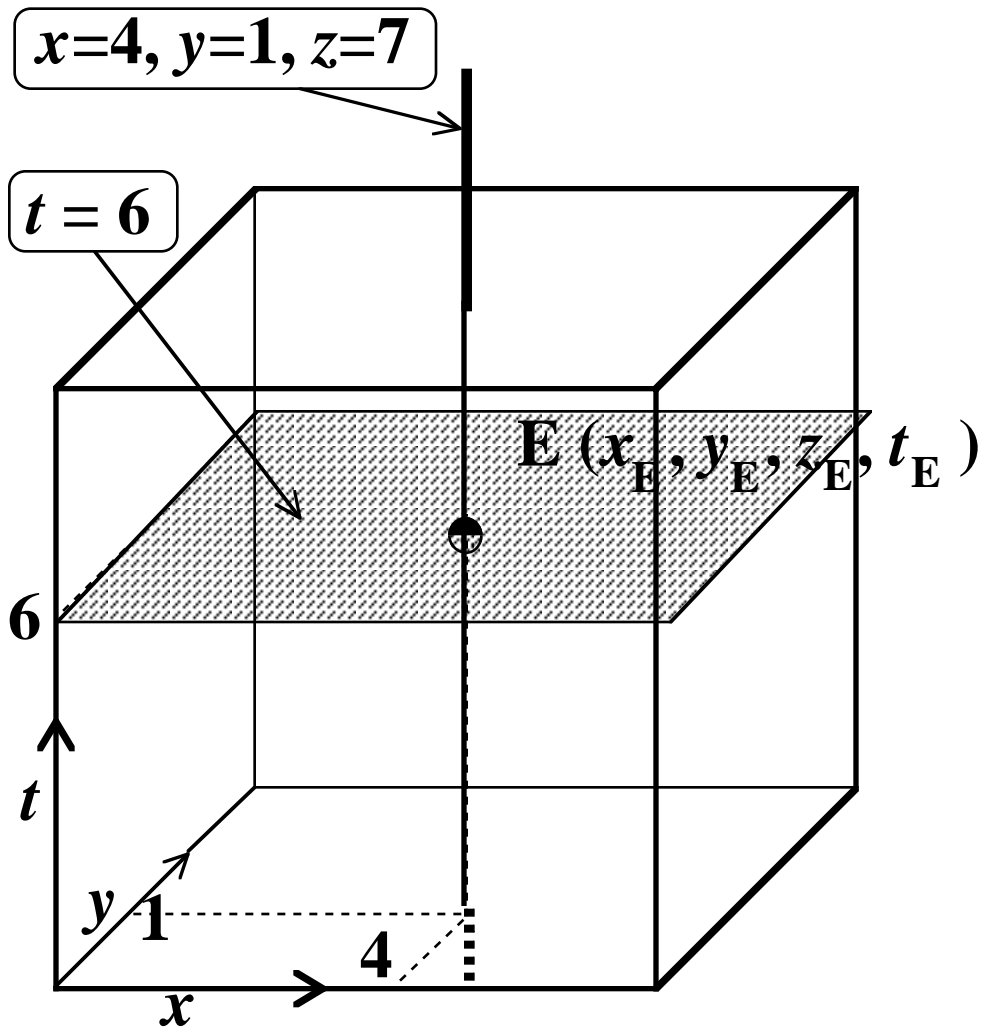

Rephrasing questions about various relationships between (among) events in the geometrical language (of lines and planes)

“Do two event have the same position in space?”

“Do two points of space-time (representing our events) lie on the same vertical straight line?”

“Do two events occur at the same time?”

“Do two points of space-time lie on the same horizontal 3-plane?”

“What is the spatial distance between two events?”

“What is the elapsed time?”

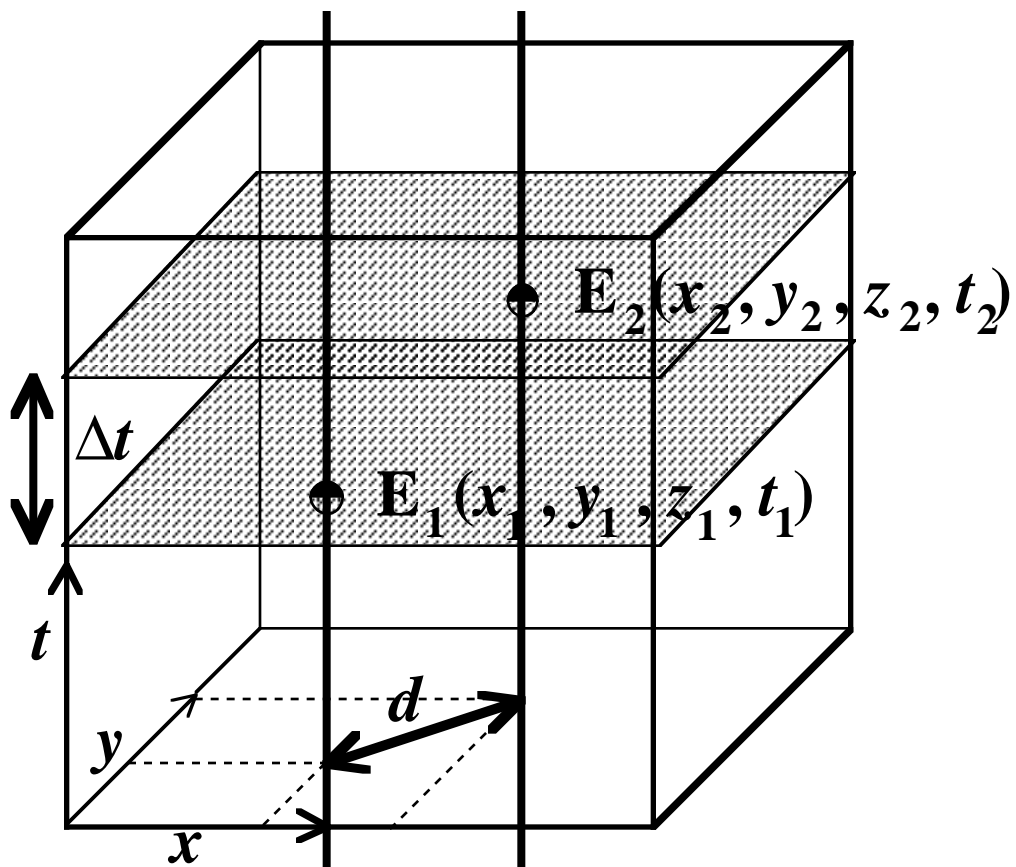

Particles in Space-Time

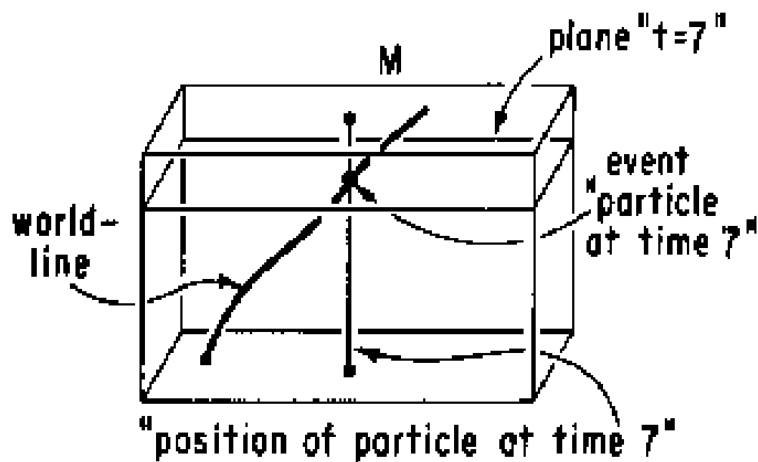

Geroch, 2-7, p. 18.

- ➔ Particle world-lines contain *all* the information about what the particle is doing and when.

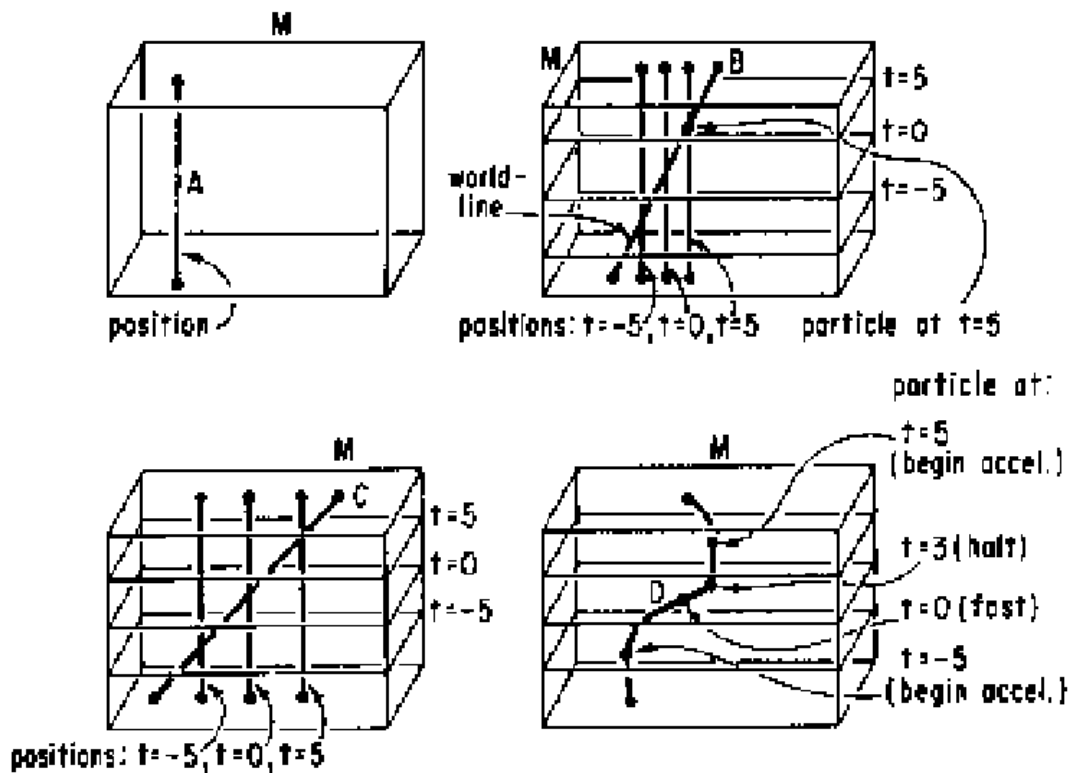

Geroch, 2-8, p. 19

“Collision”

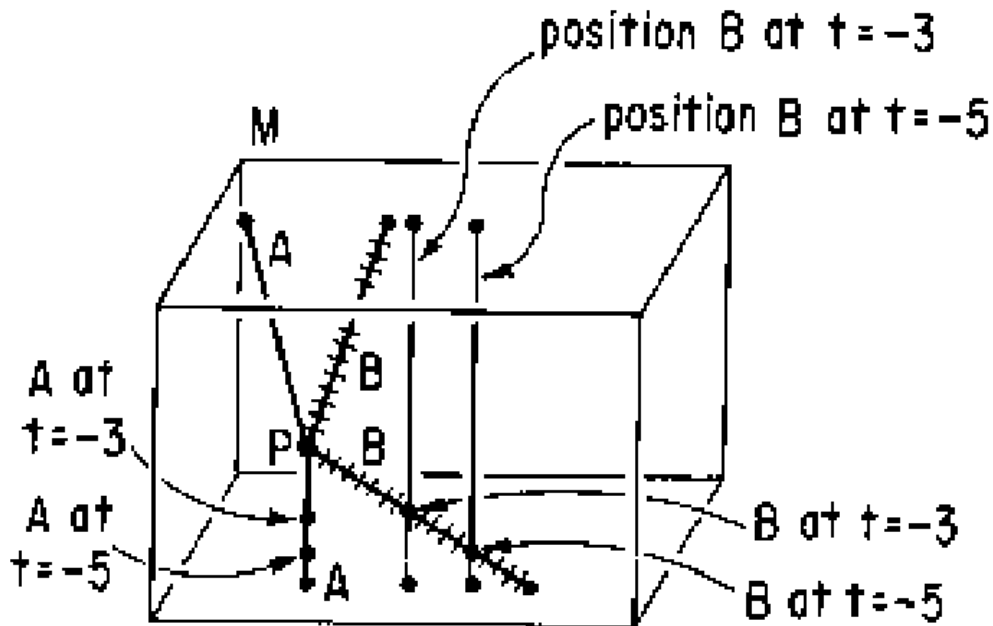

➡ Collision in space vs. collision in space-time

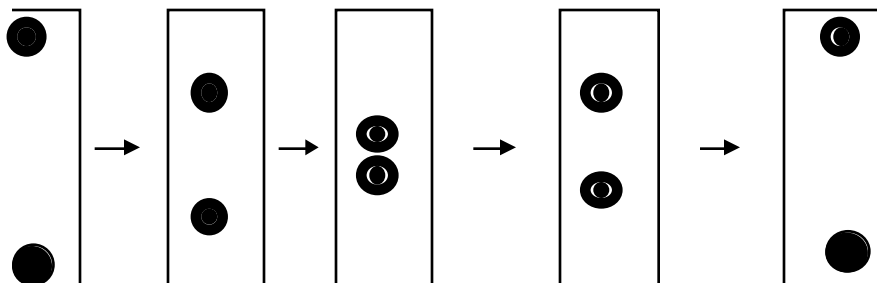

Space-time diagrams represent dynamic processes, such as motions, in a “static” way. Nothing happens within space-time itself. Things and processes just “sit” there, from time immemorial. Particles do not “move through” space-time or “follow along” their world-lines. They just *are* in space-time, once and for all, and the world-line of a particle represents, all at once, its complete life history. But the dynamics can be recovered from such a static space-time diagram if we consider the positions of objects at different moments of time and then compare them.

Spatially Extended Objects in Space-Time

Rope

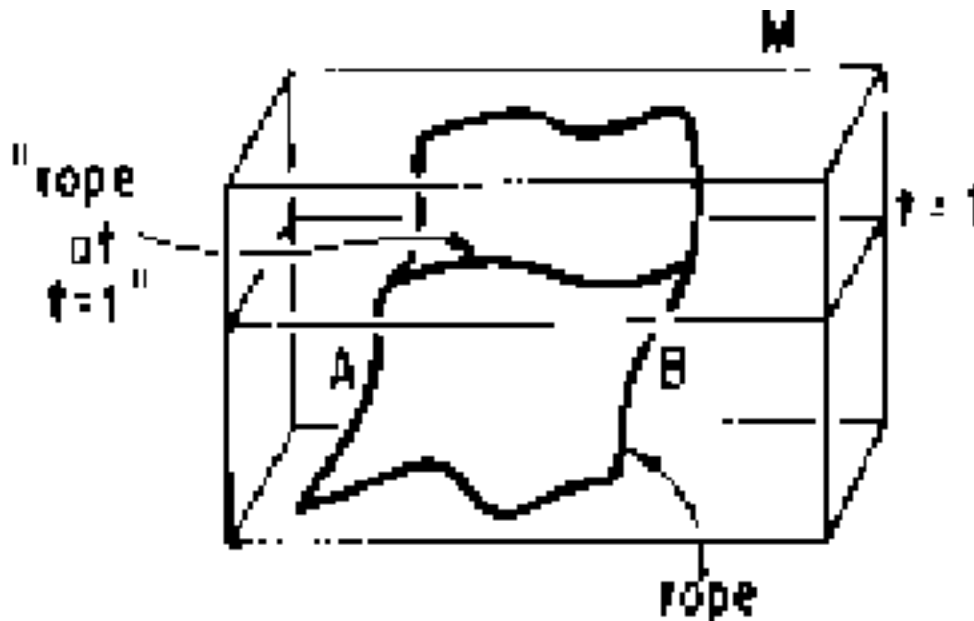

Geroch, 2-10, p. 22

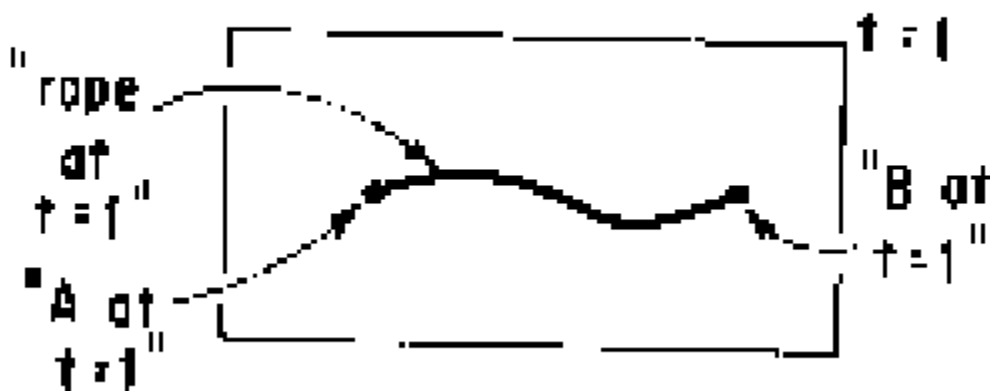

Geroch, 2-11, p. 22

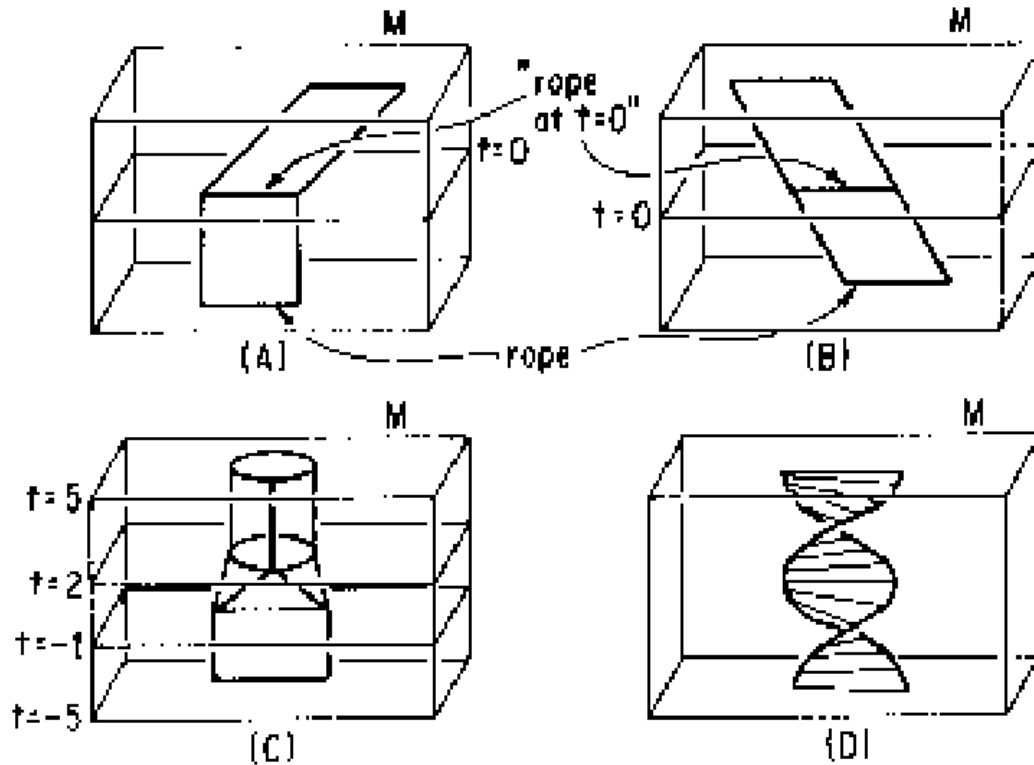

Geroch, 2-12, p. 24

Two- and Three-dimensional Objects in Space-Time

Point-like object world-line

One-dimensional object world-surface

Two-dimensional object 3D world-“surface”

Three-dimensional objects 4D world-region

World-line \cap “time-plane” = point

World-surface \cap “time-plane” = line

3D world-“surface” \cap “time-plane” = 2D area

4D world-region \cap “time-plane” = 3D volume

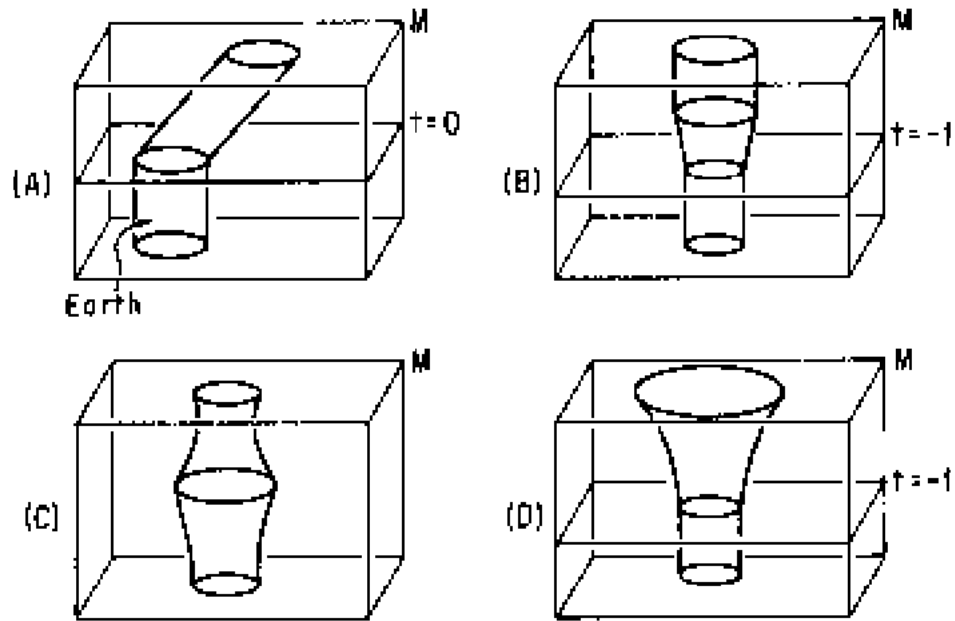

Geroch, 2-13, p. 26

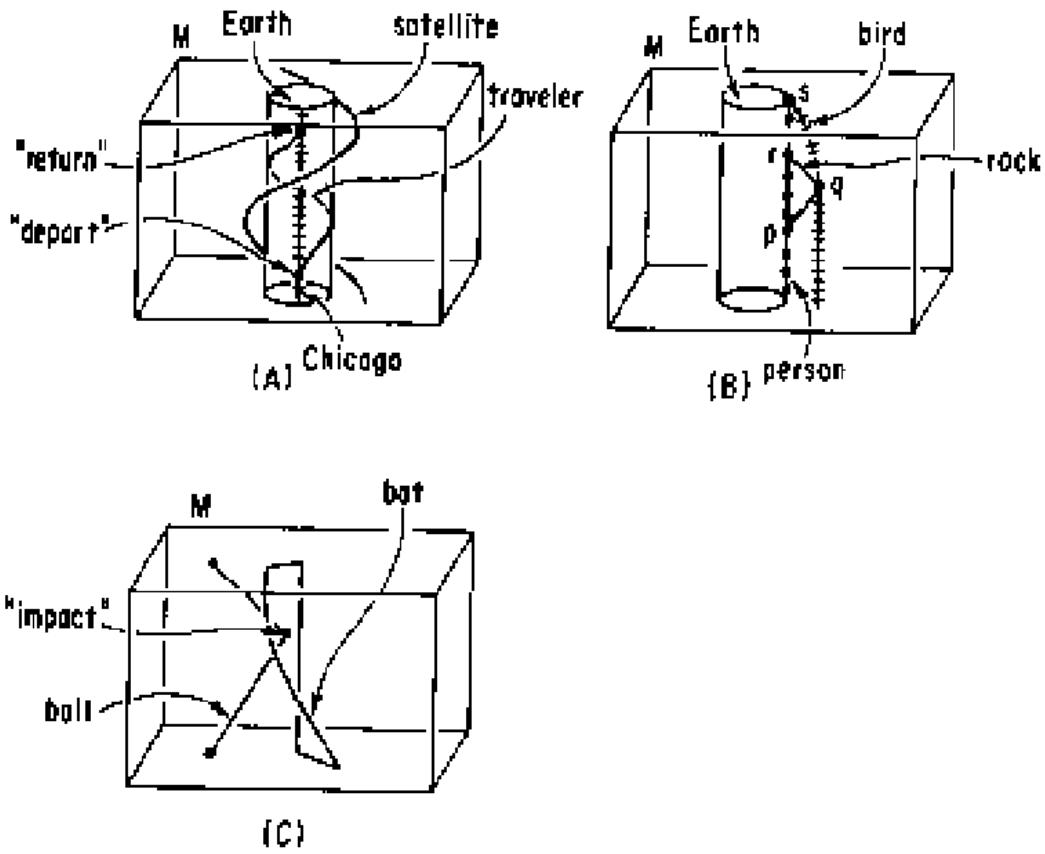

Geroch, 2-14, p. 27

Lessons

Diagrams in space-time encapsulate a *complete* information about what's going on: how objects move and otherwise change with time, how various processes occur.

Space-time diagrams represent the lives of objects and processes they undergo in a *geometrical* way, in terms of certain geometrical structures, such as world-lines or world-surfaces, or world-regions.

One can translate back and forth between geometrical constructions in space-time and physics.

What is going on here, physically speaking?

