

Length Contraction

- The spatial distance between two events is longest when measured in the reference frame in which the events are simultaneous.
- The length of an extended object is longest (*proper length*, l_0) when measured in the reference frame in which the object is at rest.
- To measure the length of an object *in a particular frame*, one has to record the coordinates of the object's ends *at the same time (in that frame)* and then take the difference.
- Alternatively, one can measure the velocity of an object (more precisely, the component of the velocity in the direction of the dimension to be measured) *in a given frame* and multiply it by the time it takes the object to pass a stationary observer.
- If the length of that object is measured in a reference frame in which the object is moving, the length is found to be contracted by the factor

$$\gamma = \frac{1}{\sqrt{1 - \frac{v^2}{c^2}}} > 1: \Delta l = \Delta l_0 / \gamma.$$

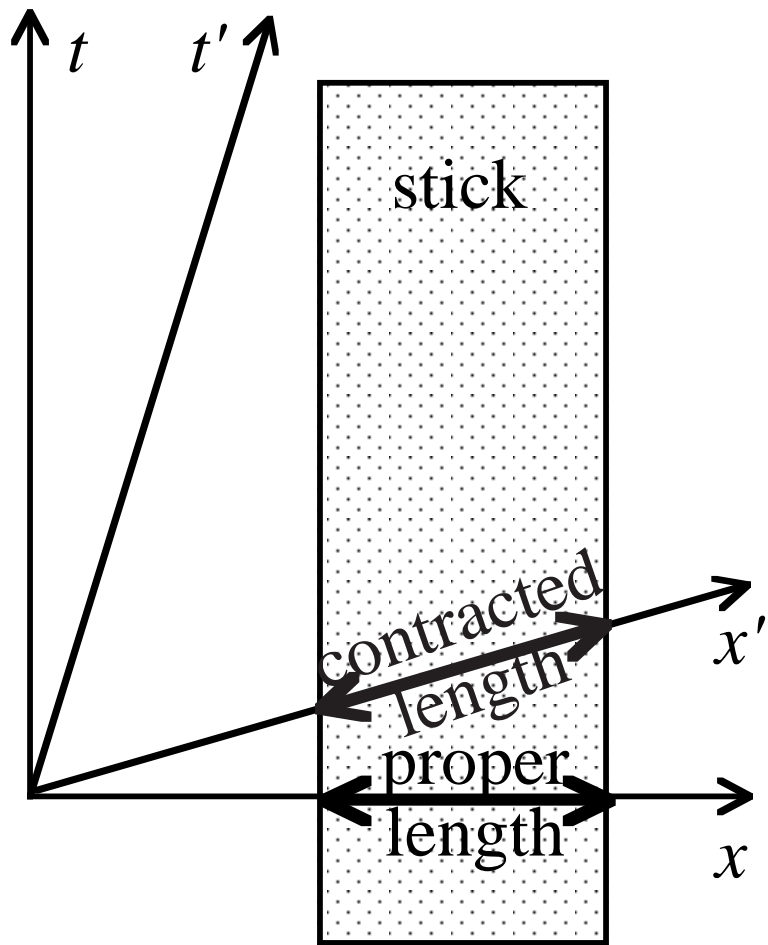

Relationship between Time Dilation and Length Contraction [Sartori, p. 84]

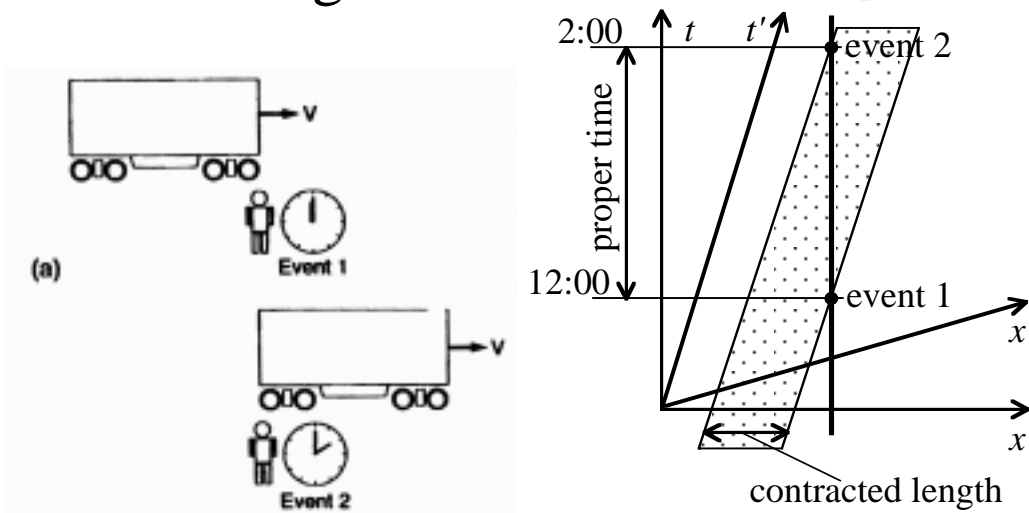

Length measured in ground frame = $V \times$ proper time
 = contracted length

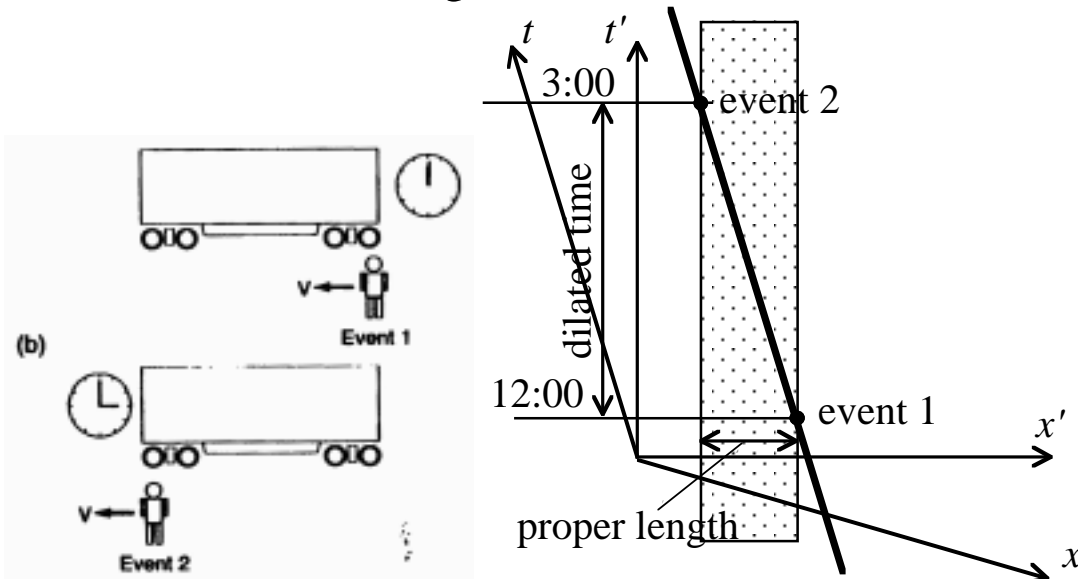

Length measured in train frame = $V \times$ dilated time =
 = proper length

$$\frac{\text{contracted length}}{\text{proper time}} = \frac{\text{proper length}}{\text{dilated time}}$$

$$\frac{\text{dilated time}}{\text{proper time}} = \frac{\text{proper length}}{\text{contracted length}} = \gamma$$

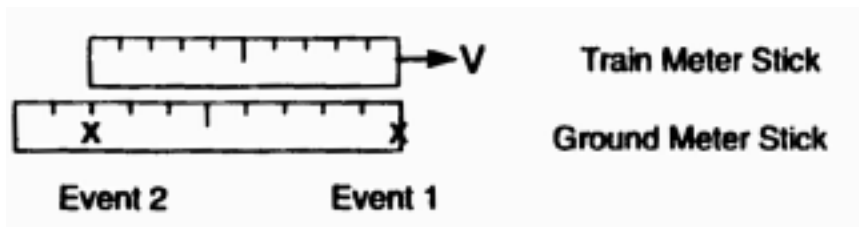

[Sartori, p. 86]

