

Last Name:

First Name:

Physics 102 Spring 2006: Final Exam —Multiple-Choice Questions

For questions 1 and 2, refer to the graph below, depicting the potential on the  $x$ -axis as a function of  $x$

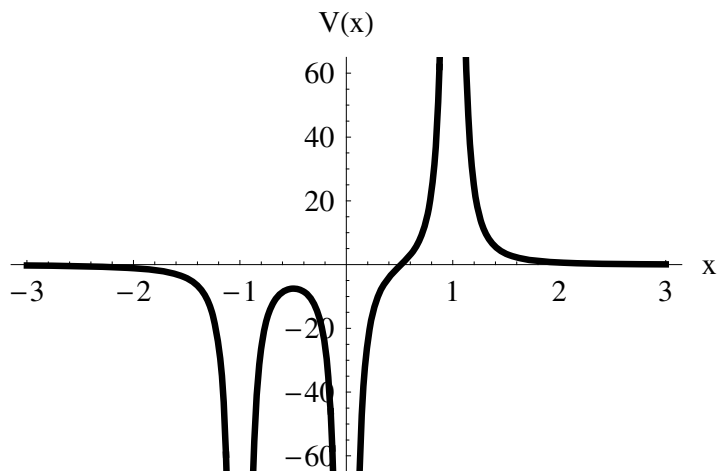

1. Which of the charge configurations depicted below would give rise to the potential shown above?

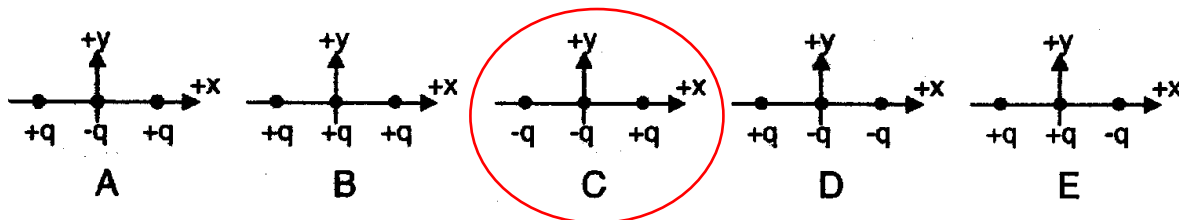

2. What is the  $x$  component of the electric field for points on the  $x$ -axis given by the potential depicted above?

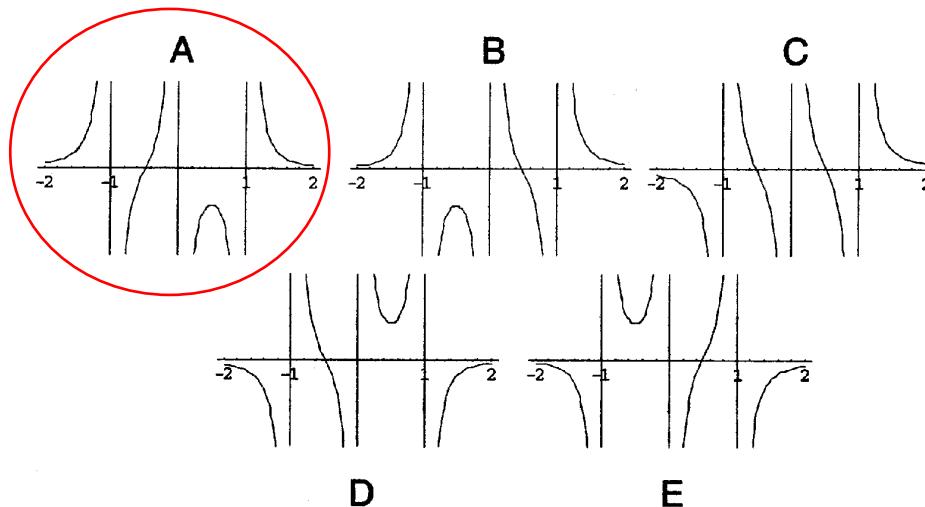

3. In each of the pictures below, the arrows represent the electric field lines and the distance between  $A$  and  $B$  is the same. Assuming the electric field is the same at point  $A$  in all cases (1 - 3), list in order from least to greatest the potential difference  $\Delta V_{AB} \equiv V(B) - V(A)$ .

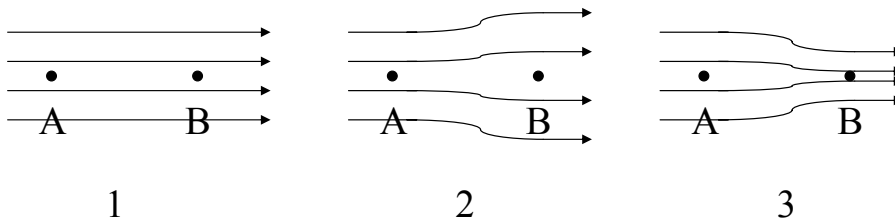

- (A) case(1) < case(2) < case(3).
- (B) case(2) < case(3) < case(1).
- (C) case(3) = case(1) < case(2).
- (D) case(2) < case(3) = case(1).
- (E) case(3) < case(1) < case(2).

4. The current through an infinitely long solenoid is increased linearly as a function of time in the direction indicated in the figure below. The figure below represents a cross section of the solenoid indicating the direction of the magnetic field. The electric field inside the solenoid is

- (A) in the form of counter-clockwise rotating circles centered on the axis of the solenoid.
- (B) in the form of clockwise rotating circles centered on the axis of the solenoid.
- (C) parallel to the axis of the solenoid.
- (D) radially directed outward from the center on the axis of the cylinder.
- (E) zero.

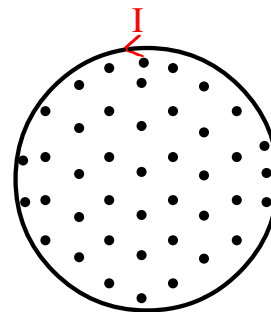

5. The switch in the circuit below has been opened a very long time. What is the current through resistor  $R_2$  immediately after the switch is closed?

- (A)  $V / R_1$ .
- (B)  $V \left[ \frac{R_1 + R_2}{R_1 R_2} \right]$ .
- (C)  $V / (R_1 + R_2)$ .
- (D)  $V / R_2$ .
- (E) 0.

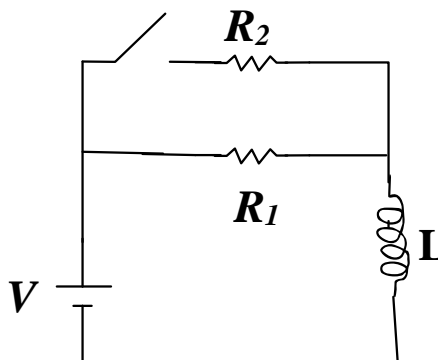

6. Consider four very long wires carrying equal steady currents going into or out of the page as indicated in the figure below. Rank the line integral of the magnetic field  $\oint \vec{B} \cdot d\vec{l}$  (from greatest to least) taken in the clockwise direction.

- (A)  $A > C > B > D$
- (B)  $D > B > C > A$
- (C)  $A = C > B = D$
- (D)  $A = B > C = D$
- (E)  $C = D > A = B$

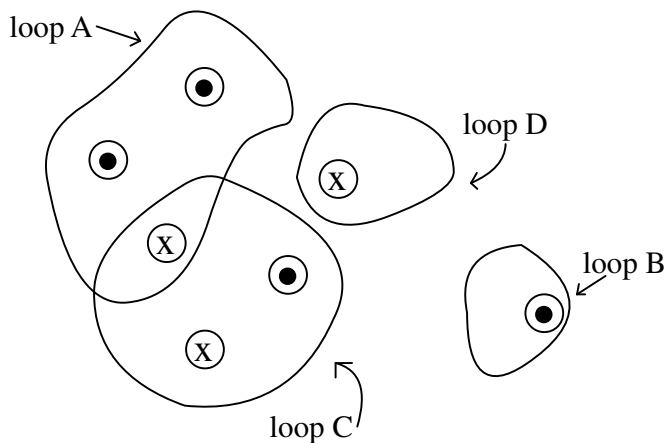

7. A capacitor is fully charged to 24 V and then connected between points A and B in the figure below, with its positive plate located at A. What is the current through the 2 kΩ resistor immediately after the capacitor is connected?

- (A) 0 mA.
- (B) 2 mA.
- (C) 4 mA.
- (D) 8 mA.
- (E) 12 mA.

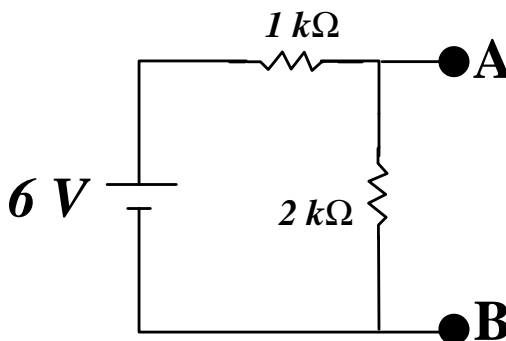

Refer to the circuit below for Questions 8 - 10. At time  $t = 0$ , the switch is closed.

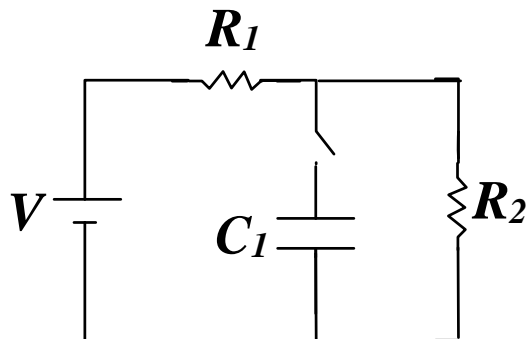

8. The current,  $I_0$ , through resistor  $R_1$  at  $t = 0$  is
- (A)  $I_0 = V/(R_1 + R_2)$ .
  - (B)  $I_0 = V/R_1$ .**
  - (C)  $I_0 = V/R_2$ .
  - (D) 0.
9. After the switch has been closed for a very long time, the potential difference,  $V_C$ , across the capacitor is
- (A)  $V_C = V$ .
  - (B)  $V_C = V(R_1/R_2)$ .
  - (C)  $V_C = V(R_2/R_1)$ .
  - (D)  $V_C = V(\frac{R_1}{R_1+R_2})$ .
  - (E)  $V_C = V(\frac{R_2}{R_1+R_2})$ .**
10. Which of the following graphs best represents the behavior of the charge on the capacitor as a function of time?

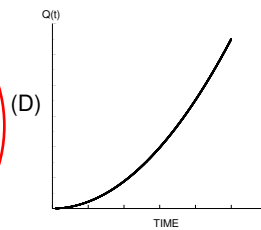
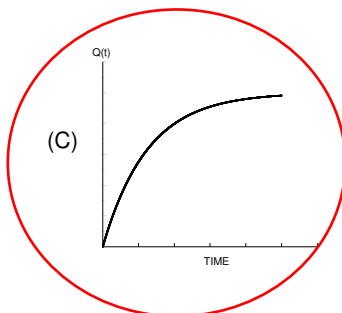
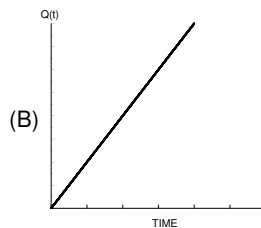
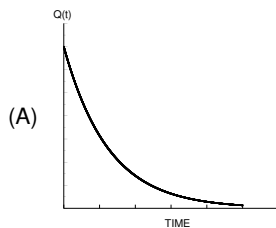

11. The figure below shows an open loop of wire in a magnetic field. There are no charged particles near the loop. Charge has piled up at the loop gap with the polarity indicated in the figure. What can be concluded?

- (A) The magnetic field strength is static.
- (B) The magnetic field strength is increasing.**
- (C) The magnetic field strength is decreasing.
- (D) There can be no charge piled up at the loop gap since this is not a closed loop.
- (E) More information is needed to answer the question.

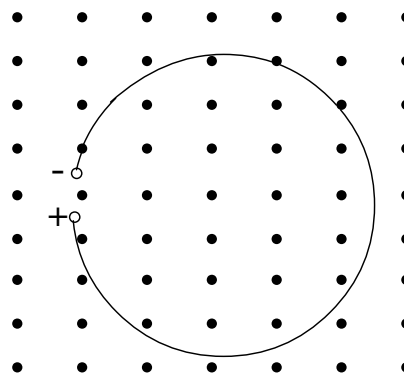

12. A loop of wire carries a constant current  $I$  in the clockwise direction when viewed from the right as shown below. A very long straight wire passes near the loop, also carrying constant current  $I$  indicated in the figure. The loop will experience a torque in what direction?

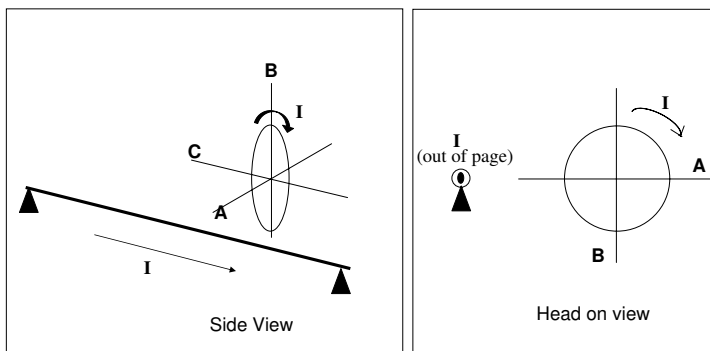

- (A) The loop experiences a net torque about axis A.**
- (B) The loop experiences a net torque about axis B.
- (C) The loop experiences a net torque about axis C.
- (D) The loop experiences no net torque.

13. Charges  $+4Q$  and  $-Q$  are situated as shown below. The net electric field is zero nearest which point?

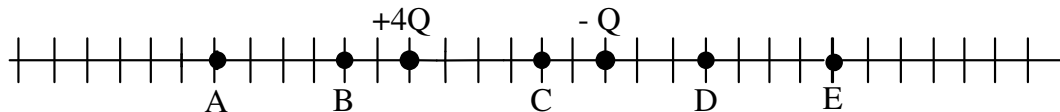

- (A) A.
- (B) B.
- (C) C.
- (D) D.
- (E) E.**

14. A neutral particle (labeled 1) in the figure below is moving with constant speed in a region of constant magnetic field (the direction is indicated in the figure). At a given instant in time, particle 1 “decays” into two different particles (labeled 2 and 3). The two particles follow paths indicated in the figure such that initially they have the same radius of curvature. Which of the following statement(s) is (are) true?

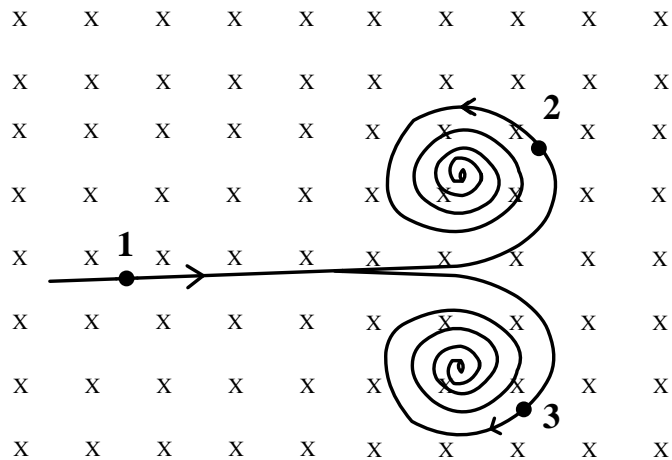

- I. The magnitude of momentum of particle 2 is less than the magnitude of momentum of particle 3.
  - II. The magnitude of momentum of particle 2 is the same as the magnitude of momentum of particle 3.
  - III. The magnitude of momentum of particle 2 is greater than the magnitude of momentum of particle 3.
  - IV. Particle 2 is negatively charged and particle 3 is positively charged.
  - V. Particle 2 is positively charged and particle 3 is negatively charged.
  - VI. The speed of particle 2 is increasing.
  - VII. The speed of particle 2 is decreasing.
- (A) Only I, IV, and VI are correct.  
 (B) Only II, IV, and VII are correct.  
 (C) Only II, V, VII are correct.  
 (D) Only I, V, and VI are correct.  
 (E) Only I, V, and VII are correct.

15. The figure below shows two arcs of equal radius centered about point P. Positive charge  $+Q$  is uniformly distributed on the upper arc and negative charge  $-Q$  is uniformly distributed on the lower arc, as indicated in the figure below. Which arrow best indicates the direction of the electric field at point P, the center of the arcs?

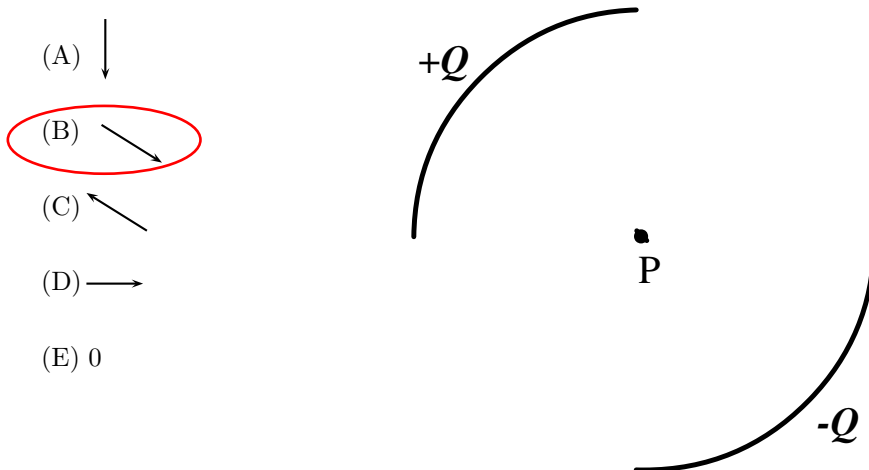

16. A solenoid has an inductance  $L_0$ . A second solenoid is identical to the first except that its geometrical dimensions have been magnified by a factor of two and the total number of loops remains the same. What is the ratio of the inductance of the magnified ( $L_1$ ) solenoid to the original solenoid (i.e., what is  $L_1/L_0$ )?

- (A) 4.
- (B) 2.
- (C) 1.
- (D) 1/2.
- (E) 1/4.

17. Doubling which of the following quantities quadruples the energy stored in an ideal solenoidal inductor:

- I. current.
- II. length.
- III. radius.
- IV. loops per length.

- (A) Only I and II.
- (B) Only I and III.
- (C) Only I, II and III.
- (D) Only I, III and IV.
- (E) All four.

For Questions 18 - 20 refer the figure below. Originally there were eight *negative* charges held equally around a circle of radius  $R$ . One of the charges is removed and the charge configuration is illustrated in the figure below.

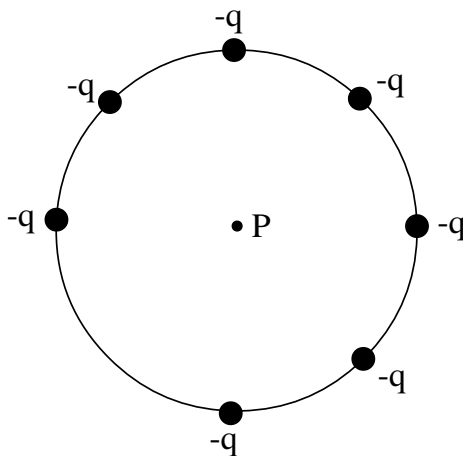

18. What is the magnitude of the electric field at the center of the circle?
- (A) 0.  
(B)  $(1/8) k q / R^2$ .  
(C)  $(7/8) k q / R^2$ .  
(D)  $k q / R^2$ .  
(E)  $7 k q / R^2$ .
19. What is the direction of the electric field at the center of the circle?
- (A) ↓  
(B) ↗  
(C) ↙  
(D) →  
(E) 0
20. What is the electric potential at the center of the circle? (Assuming the electric potential approaches zero at a infinite distance away from the center of the circle).
- (A) 0.  
(B)  $-(1/8) k q / R$ .  
(C)  $-(7/8) k q / R$ .  
(D)  $-k q / R$ .  
(E)  $-7 k q / R$ .



21. Two transformers are arranged as shown below and the power cord is “plugged” into a 120 V AC voltage source. The number of turns  $N_2$  is *twice* as large as the number of turns  $N_1$ . If 1 Amp of current is measured in the intermediate wire (the wire containing  $N_2$  turns), what is the current through the light-bulb?

- (A) 1/4.
- (B) 1/2.
- (C) 1.
- (D) 2.**
- (E) 4.

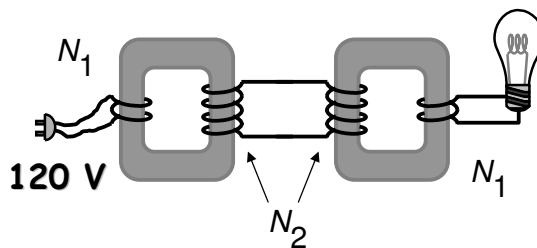

22. The leads of an AC-generator with angular frequency  $\omega$  and peak voltage  $V_p$  are connected across a capacitor with capacitance  $C$  and reactance  $X_C = 1/\omega C$ . What is the average power  $\langle P \rangle$  dissipated by the capacitor?

- (A)  $\langle P \rangle = 0$ .**
- (B)  $\langle P \rangle = V^2/(\sqrt{2} X_C)$ .
- (C)  $\langle P \rangle = V^2/(2 X_C)$ .
- (D)  $\langle P \rangle = V^2/(X_C)$ .
- (E)  $\langle P \rangle = 2V^2/(X_C)$ .

23. Two resistors and an inductor are connected across an AC voltage source as shown below. As the frequency of the AC voltage source increases, the RMS current in the resistor labeled  $R_2$

- (A) increases.**
- (B) remains the same.
- (C) decreases.

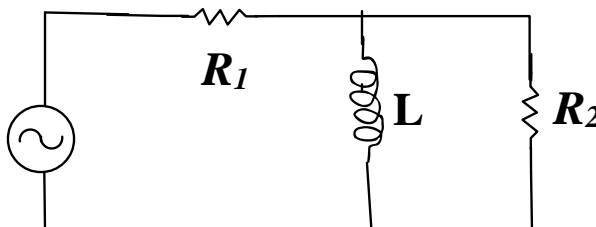

24. Three very long wires carrying constant current of equal magnitude and directions as indicated in the figure below are held in place. Which arrow best represents the direction of the force experienced by the wire located at the point  $(x = 0, y = b)$ ?

- (A) ↓
- (B) ↑
- (C) ←
- (D) →**
- (E) 0

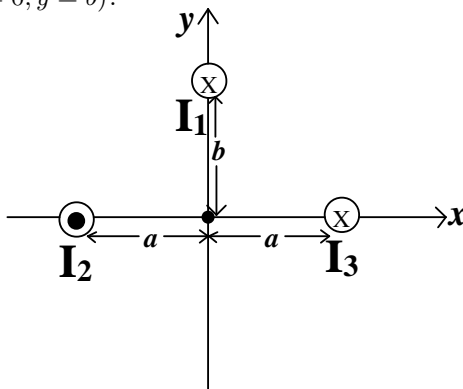

25. Four positively charged particles with equal charge,  $+Q$  are situated near a very long wire carrying a negative uniform linear charge density,  $-\lambda$ . A sphere of radius  $R$  is centered about point  $P$  indicated in the figure below. The electric flux,  $\Phi_E = \oint \vec{E} \cdot d\vec{A}$  through the sphere is:

- (A)  $\Phi_E = 0$ .  
(B)  $\Phi_E = \frac{8Q\pi R^2 - 4\lambda\pi R^2}{\epsilon_0}$ .  
(C)  $\Phi_E = \frac{2Q - 2\lambda R}{\epsilon_0}$ .  
(D)  $\Phi_E = \frac{-2\lambda R}{\epsilon_0}$ .  
(E)  $\Phi_E = \frac{2Q}{\epsilon_0}$ .

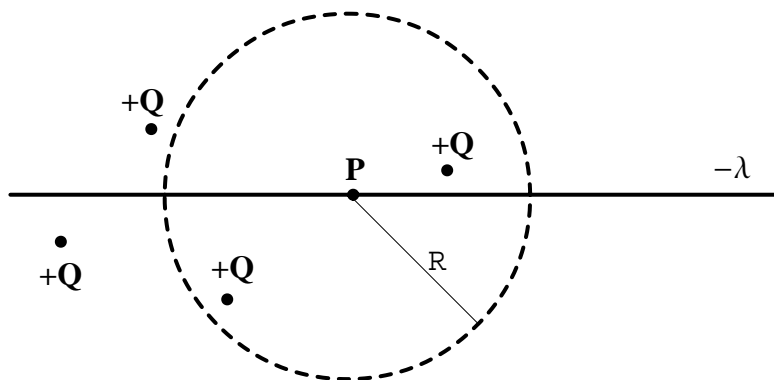

Last Name: **KEY**

First Name: **KEY**

---

Physics 102 Spring 2006: Final Exam —Multiple-Choice Answers

	A	B	C	D	E
1			X		
2	X				
3					X
4		X			
5					X
6					X
7					X
8		X			
9					X
10			X		
11		X			
12	X				
13					X
14			X		
15		X			
16		X			
17				X	
18				X	
19		X			
20					X
21				X	
22	X				
23	X				
24				X	
25			X		