

Deflection of Electrons

Every statement in physics has to state relations between observable quantities.

E. Mach (1838-1916)

OBJECTIVES

To determine the effect of electric and magnetic fields on a beam of electrons. To measure the charge to mass ratio of an electron.

THEORY

In this exercise we ask how a stream of negatively charged particles responds to electric and magnetic fields, and thereby determine the speed of the particles and their charge to mass ratio. Consider a beam of particles with charge e and mass m , moving at speed u through a vacuum. If there is a uniform electric field \vec{E} and uniform magnetic field \vec{B} , The force on each particle is given by

$$\vec{F} = e\vec{E} + e\vec{u} \times \vec{B} \quad (1)$$

We might choose to produce the \vec{E} field with a voltage applied to two parallel plates, and to produce the \vec{B} with a coil outside the vacuum chamber. In either case, the fields are calculable from the geometry, shown in Fig. 1, and measurable voltages and currents. For simplicity, we consider only one field at a time, and calculate the deflection of the beam when we turn on each field.

The electric field causes a constant transverse acceleration during the time the particles are between the plates. The force acting is simply eE , and the time is $\Delta t = L_p/u$, so the particles acquire a velocity u_1 , perpendicular to u , given by

$$u_1 = \frac{F}{m} \Delta t = \frac{e}{m} \frac{EL_p}{u} \quad (2)$$

After leaving the plates the particles travel in a straight line to the end wall of the tube. The path makes an angle θ with the original direction, resulting in a displacement D_E given by

$$D_E = L_E \tan \theta = L_E \frac{u_1}{u} \quad (3)$$

The electric field can be expressed in terms of the voltage V_d applied to the plates by $E = V_d/a$. Using this result in Eq. 2 and 3, we get

$$D_E = \frac{e}{m} \frac{L_E L_P}{a u^2} V_d \quad (4)$$

Since the tube wall glows where the beam hits, we can measure D_E with a ruler. (There is also a small displacement that occurs within the plates, given by $eE(\Delta t)^2/2m$. This is only about 5% of D_E for the geometry we will use, and is neglected.)

From Eq. 1, the magnetic force is constant and perpendicular to \vec{u} . The particles will move in a circle whose radius may be found by equating the magnetic force to the centripetal force needed to move in a circle of radius R

$$euB = \frac{mu^2}{R} \quad (5)$$

or

$$R = \frac{mu}{eB} \quad (6)$$

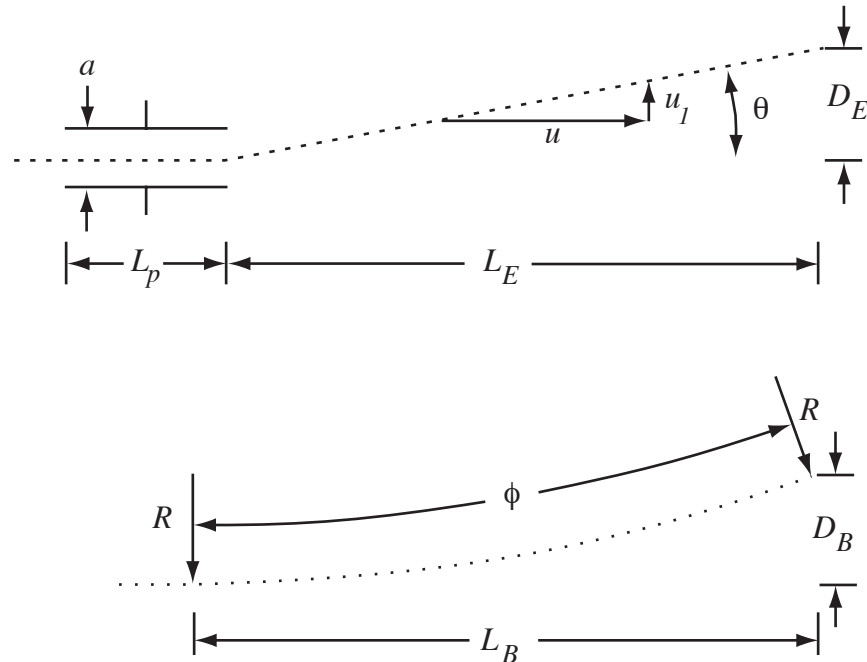

Fig 1 Arrangements for electric or magnetic deflection of charged particles. The magnetic field is uniform over the entire distance L_B , while the electric field exists only between the plates.

Referring to Fig. 1 again, the total deflection D_B is given by

$$D_B = R - R \cos\phi \quad (7)$$

For small angles, we can use the approximations $L_B \approx R\phi$ and $\cos\phi \approx 1 - (\phi^2/2)$ to combine Eq. 6 and Eq. 7 into

$$D_B = \frac{e L_B^2}{m 2u} B = \frac{e L_B^2}{m 2u} GI \quad (8)$$

In the last part we expressed the field B by $B = GI$, where I is the current in the coils and G is a geometric factor that will be given later.

Eqs. 4 and 8 are our main results. They tell us that graphs of D_E vs V_d and D_B vs I will be straight lines with specified slopes. Calling the slopes s_E and s_B respectively, we can solve for the two unknowns u and e/m , to arrive at

$$u = \frac{2L_p L_E s_B}{aGL_B^2 s_E} \quad \text{and} \quad \frac{e}{m} = \frac{4L_p L_E s_B^2}{aG^2 L_B^4 s_E} \quad (9)$$

These two equations will be used for analyzing our data.

EXPERIMENTAL PROCEDURE

Figure 2 is a sketch of the vacuum tube that we will use, showing the electrical connections needed. Electrons are boiled out of the cathode with a heater. Various electrodes, labeled as grids and anodes, form the stream of electrons into a focused beam. The voltage labeled C- is adjusted to provide the proper focus, while the B+ and C- voltages together determine the energy and speed of the electrons. After leaving the accelerating and focusing electrodes, the beam passes between two sets of deflecting plates which are arranged to deflect the beam in orthogonal directions. As shown in Fig. 2, we will use only the second set, nearer the screen. The other set is connected to the anode so it will not charge up and produce undesirable deflections. After the deflection plates, the beam travels a distance L_E to the end of the tube, where it causes a special material to glow at the point of impact. The coils which produce the magnetic field will be discussed later. Table 1 contains a summary of the constants you will need.

Before proceeding with the experiment, there is a hazard you must be aware of. The power supply used here produces dangerously high voltage. Because of this it has two control

switches. The AC POWER switch turns on the supply and the low voltage outputs. It may be left on throughout the experiment. The DC ON/STANDBY switch controls the high voltage. This switch must be at STANDBY when you make any changes in the wiring. Failure to follow this procedure may result in a dangerous electrical shock. It is good practice to set the switch to STANDBY any time you are not actually making measurements.

Check that the tube and deflection circuits are connected as shown in Fig. 2. Turn on the AC POWER switch and set the deflection voltage to zero. Allow the heater to warm up for about a minute, and then turn on the DC with the DC ON switch. The VOLT METER switch connects the meter on the power supply to either the B+ VOLTS (red scale) or the C- VOLTS (black scale). Note that the B+ and C- potentials are relative to the COM (i.e. common) terminal. This means that, for

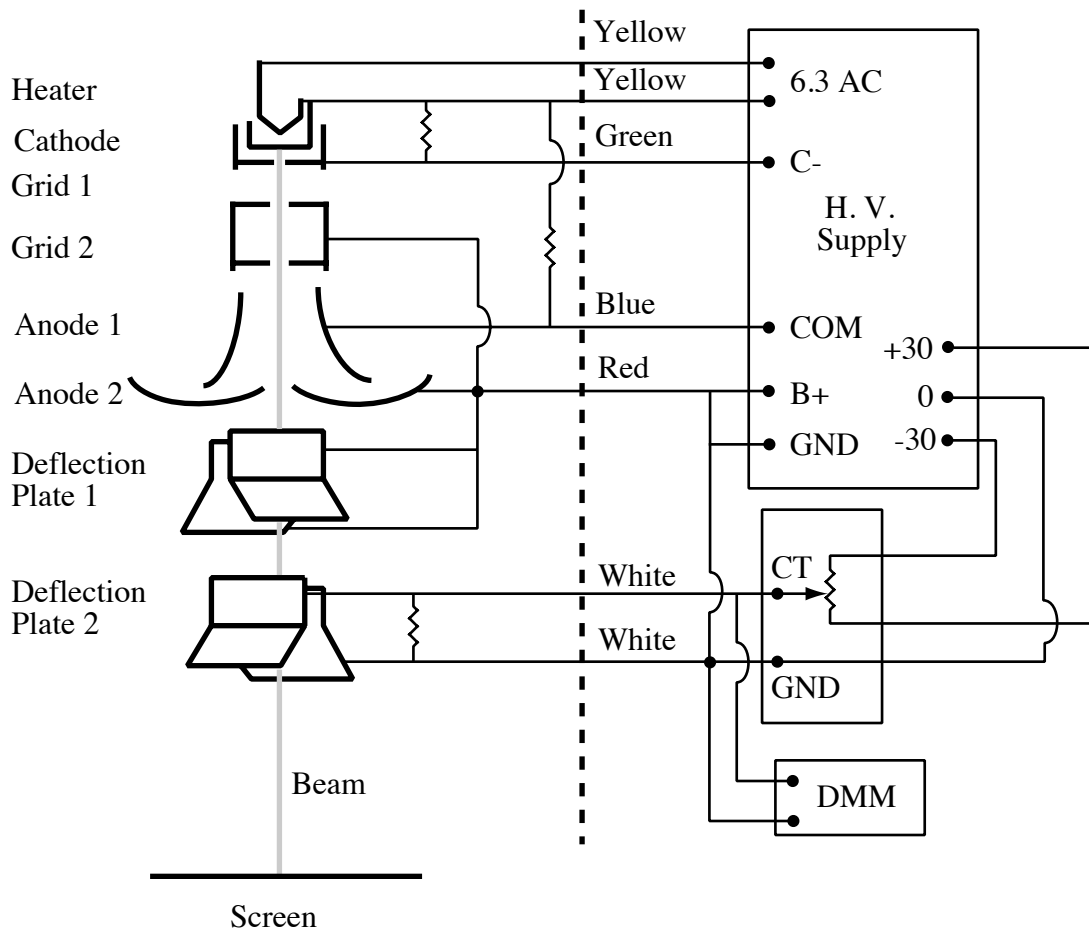

Fig. 2. Electrode configuration and wiring diagram for the cathode ray tube (CRT). Wiring to the left of the dashed line is already in place inside the tube mounting. The voltage divider circuit driving the deflection plates is contained in a separate box which must be connected to GND as shown. Connect leads to the DMM terminals marked $V\Omega$ and COM and set the large knob to point at the V with the solid and dashed lines over it.

example, anode 1 will be at a potential B+ more negative than anode 2 (which is at ground potential). Set the B+ to about 250 V, and then adjust the C- to get the sharpest possible spot on the face of the tube. Try several settings of the B+ to find the largest value for which you can get a sharp spot, and the lowest value for which the spot is bright enough to easily see. You will have to adjust the C- voltage to focus at each B+ setting. Note the largest and smallest values of B+ that your tube allows. These correspond to the range of speeds u that are available, and will be used in the deflection measurements.

There are two extraneous effects that you may notice. The first is that the position of the beam spot depends on the orientation of the tube. This occurs because the earth's magnetic field deflects the beam. Pick an orientation which places the spot conveniently and do not move the tube during a series of observations. The second effect is the complete disappearance of the spot when operating at low B+ voltage. At higher voltages electrons will be ejected from the screen as fast as they arrive, maintaining charge neutrality. At low voltages the screen may become charged, thereby defocusing and repelling the beam. The problem can be cured by temporarily increasing the beam voltage and then lowering it again for a quick measurement.

Electric deflection

With the tube focused at the highest B+, increase the deflection voltage V_d . The spot on the tube face should move vertically in response to the electric field. Measure the deflection D_E for a few values of V_d , and plot D_E as a function of V_d . Reset the B+ to the lower value you found and repeat the measurement, plotting the new data on the same graph. The slopes of these two lines are the values of s_E for two different values of u . Set the power supply to STANDBY and proceed to the magnetic deflection.

Magnetic deflection

Disconnect the two white leads and the DMM from the voltage divider box. To prevent deflection plate 2 from accumulating a negative charge, connect both white leads from the tube to the GND terminal on the high voltage power supply. These procedures assure that there will be no stray electric fields to deflect the beam.

L_p	1.5×10^{-2} meter
L_B	1.6×10^{-1} meter
L_E	1.2×10^{-1} meter
a	4.0×10^{-3} meter
G	4.1×10^{-3} Tesla/Amp

Table 1 Tube and Coil Constants

Position the tube on the plywood platform between the coils so that the region between the end of the electron gun and the screen is centered between the coils. The magnetic field will be approximately uniform in this region. Connect the coils, the low voltage power supply and the DMM so that current flows sequentially through each. The DMM will measure current flowing through the terminals labeled mA and COM when the large knob points at the mA with the solid and dashed lines over it. The field is proportional to the current read on the DMM, with constant of proportionality G listed in Table 1.

Turn on the high voltage DC, with no current in the coils, and set the B+ to the higher value. As you turn up the current in the coils, the spot should deflect. If the spot moves only slightly or becomes defocused, reverse the connections on one of the coils and try again. Measure the deflection D_B for a few values of current I , and plot D_B as a function of I . Repeat the procedure for the lower B+ voltage, plotting the data on the same graph. Don't forget to adjust C- for focus. When you have both sets of data, turn off the high voltage with the DC ON/STANDBY switch.

Analysis

You now have values of s_E and s_B for two different values of u . Use Eq. 9 and the constants in Table 1 to obtain two estimates of e/m and two values of u from your data. If you use MKS units throughout, your answers will automatically come out in coulombs/kilogram and meters/sec respectively. For the conditions we are using, u will be about 10^7 m/s and of course will increase with increasing B+ voltage. The accepted value of e/m is 1.76×10^{11} coulombs/kg, and should be the same for any value of u . Your number may not be very precise but it will be clearly different than $e/M = 9.42 \times 10^7$ coulombs/kg found for hydrogen in chemical experiments.