

1. The figure below shows a system that consists of a CPU and a single class of jobs that access two disks over a network. Assume that the system can be modeled as a product form network, with fixed routing probabilities as given in the figure and the following mean service times:

$$\frac{1}{\mu_{term}} = 50 \quad \frac{1}{\mu_{cpu}} = 5 \quad \frac{1}{\mu_{net}} = 1 \quad \frac{1}{\mu_{disk1}} = 20 \quad \frac{1}{\mu_{disk2}} = 10$$

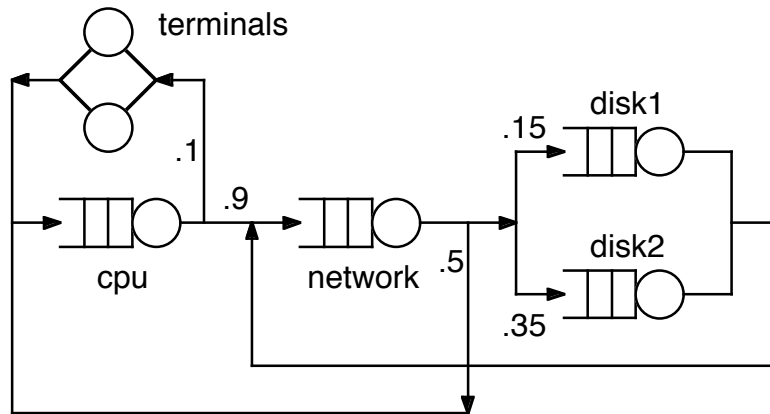

Each of the three jobs in the system has its own terminal. What is the average number of jobs at the three terminals combined?

The routing chain matrix for the system is

$$\underline{\underline{P}} = \begin{bmatrix} 0 & 1 & 0 & 0 & 0 \\ 0.1 & 0 & 0.9 & 0 & 0 \\ 0 & 0.5 & 0 & 0.15 & 0.35 \\ 0 & 0 & 1 & 0 & 0 \\ 0 & 0 & 1 & 0 & 0 \end{bmatrix}$$

$$\underline{\underline{V}}\underline{\underline{P}} = \underline{\underline{V}} \Rightarrow \begin{aligned} 0.1V_{cpu} &= V_{term} &\Rightarrow V_{cpu} &= 10 \\ V_{term} + 0.5V_{net} &= V_{cpu} &\Rightarrow V_{net} &= 2(V_{cpu} - V_{term}) = 18 \\ 0.15V_{net} &= V_{disk1} &\Rightarrow V_{disk1} &= 2.7 \\ 0.35V_{net} &= V_{disk2} &\Rightarrow V_{disk2} &= 6.3 \end{aligned}$$

Use MVA to find the expected queue lengths:

	$N = 0$	$N = 1$	$N = 2$	$N = 3$
R_{cpu}		50	60.6383	71.9453
R_{net}		18	19.3787	20.5248
R_{disk1}		54	66.4085	79.9563
R_{disk2}		63	79.8894	99.4297
X		0.004255	0.007238	0.009321
Q_{cpu}	0	0.2128	0.4389	0.6706
Q_{net}	0	0.07660	0.1403	0.1913
Q_{disk1}	0	0.2298	0.4807	0.7453
Q_{disk2}	0	0.2681	0.5782	0.9268

The average number of jobs at the terminals is $3 - (0.6706 + 0.1913 + 0.7453 + 0.9268) = 0.466$